



Self-Leveling
Rotational Laser

TABLE OF CONTENTS

Rotational laser T310		Technical information	16
Introduction	2	Dimensions	17
Safety information	2	Laser beam receiver R310	
Information about batteries/rechargeable batteries	3	Operation	18
Care	3	Setup menu	19
Maintenance	4	Status and error messages	20
Disclaimer of liability	4	Structure of the receiver	21
Proper use	4	Magnetic foot and magnetic stand adapter	21
Transport lock	5	Remote controls RC310	
Operating elements	6	General information	22
Signals	7	User information	22
Structure	12	Communication between RC310 remote controls and R310 sensor	23
Field calibration	13	Operation	24
Exchanging Batteries	15	Accessories/Part Nos.	26

ROTATIONAL LASER T310

Introduction

Congratulations on selecting your Status Pro Leveling System T310. We hope to be able to fulfil your expectations of a modern system. Before conducting your first measurement you should read and observe the safety information and precautionary measures.

We wish you success when using your new measuring device.

Safety information

The laser classification is class 2. (SS_EN_60825-1: 1994) Class 2 is considered safe for use if the following minimum precautions are observed:



Attention!

- Do not look directly into the laser beam.
- Do not point the laser beam at other persons.
- Observe the common accident protection regulations or in-company regulations. In case of doubt, consult a qualified security officer.
- The appliance is not to be operated in humid rooms.
- Avoid direct exposure to heat, e.g. sun light.
- Humidity and rain as well as extreme heat or cold have a negative effect on the appliance.



Note

Do not drop the appliance or expose it to strong vibrations. The sensitive mechanical and optical system might be damaged and distort the measuring results.
Do not touch the rotating parts during operation!

The system complies with the following norms and directives:

- SS-EN-60825-1-1994
- British Standard BS 4803 Parts 1 to 3
- Deutsche Industrie Norm DIN JEC 76 (CO) 6
- USA FDA Standard 21 CFR, Ch 1, Part 1040.10 and 1040.11



Danger!

Normal batteries must not be charged, heated or thrown into open fire (danger of explosion!). Do not insert different batteries/rechargeable batteries.
Always use one kind of the respective type! Never use old and new batteries/rechargeable batteries together.



Note

Protect your environment! Discharged batteries and rechargeable batteries should not be disposed of along with domestic rubbish. You may dispose of them at a collecting station for used batteries or special refuse. Information is available at qualified locations!

Information about batteries/rechargeable batteries

If the appliance is not used for an extended period of time, or is only operated with line voltage, the batteries or rechargeable batteries must be removed. This prevents leaking, destruction of the batteries /rechargeable batteries and thus damage to the appliance.

1. The rechargeable batteries normally require ca. 10 hours for a complete charging cycle.
2. Rechargeable batteries, if properly used, have an average lifetime of ca. 1.000 charging cycles. After that, and possibly even before that, reduced capacity may occur. Therefore, replace the rechargeable batteries when their capacity is decreasing (shorter operating time).

The appliance may be operated with power supply BG 800003 or bus supply module FIX 1-0632.

Care

T310 has been developed for industrial use; it is protected against spray water and dust. To clean the body use a soft cotton cloth, if necessary gentle soap. The receiver surface should be cleaned with a lint-free cloth only.

To clean the receiver surface, do not use paper tissues or materials that might scratch the detector surface. For optimal operation ensure that the receiver surface and the connections are not soiled or get into contact with oil or grease.

Maintenance

The mechanical parts of the appliance are exposed to natural wear. In case of trouble contact the manufacturer. Do not open the appliance without authorization.

In case of unauthorized manipulation of the appliance any warranty is voided. The appliance must always be stored in a dry place. Transport appliance only in its original case.



Note

In order to facilitate identification of your appliance for customer service purposes please always submit the serial number stated on the type label. The manufacturer shall not be liable for damage caused by improper maintenance and repair work carried out by third parties.

Disclaimer of liability

Status Pro GmbH shall not be liable for any damage caused by improper use. Proper use includes familiarity with this manual. Therefore carefully observe all the instructions in this manual and in the technical documents of the sensors. We shall assume no responsibility for errors resulting from non-observance of the operation instructions.

Proper use

The T310 leveling laser is a self-leveling rotational laser for measuring

- Straightness
- Flatness
- Level
- Plumb line / surface
- Parallelism

On industrial machines and compound machinery. Unlike with conventional appliances, measuring can be conducted by one person.



Attention!

The T310 may be operated only for the purposes described above. Improper use or use of unsuitable components (holders, tripods etc.) or modifications concerning the proper use may result in faulty operation, for which Status Pro GmbH does not assume liability.

Transport Protection Screw

The transport protection screw “S” must always be screwed in when the system is transported. Check: Examine tilted position (see picture).

Part No. T310: BG 830200/1

Part No. adapter: BG 830205

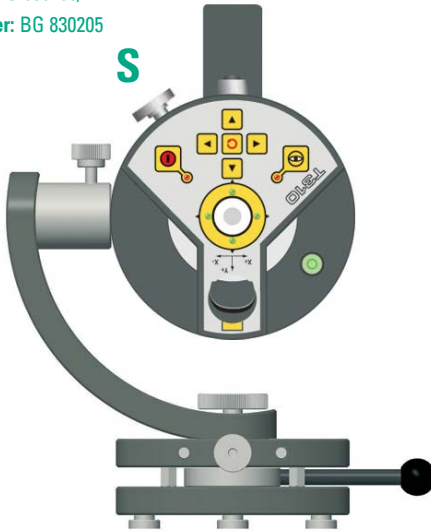

The laser sender recognizes an unloosened transport lock “S” when switched on. This is indicated acoustically by a sound signal at 5 Hz; the system cannot be used.



Attention!

Do not screw transport protection screw “S” in too deeply! The laser head may be damaged. It is sufficient if the laser head, as shown, is slightly tilted.



Note

Before switching on the laser sender the transport lock “S” must be loosened, so that the laser head moves from tilted position into measuring position. The laser head must not be obstructed by the transport lock when rotating.

Remove the transport lock by turning it counter-clockwise to the stopping point.

Do not turn out any further, as otherwise the transport lock might be damaged.

ROTATIONAL LASER T310

Operating elements

Overview T310

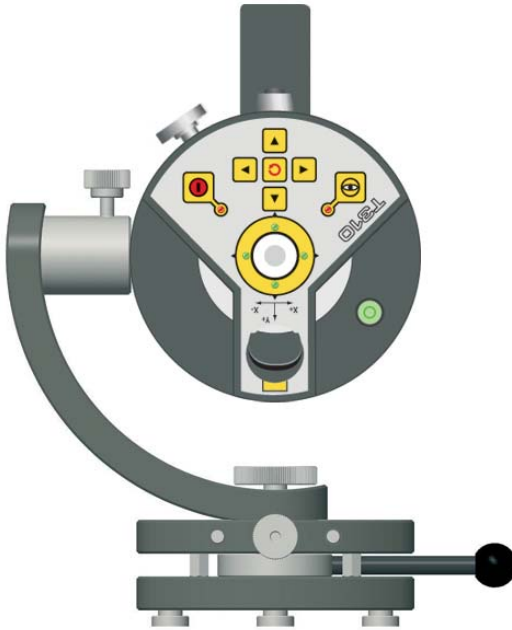









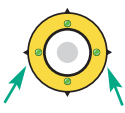

Operation T310

The operating keys control various functions.

In addition, the LEDs serve as display.

A complete description of the displays can be found in Chapter "Signals of T310" from p. 7.

-  1. IR-receiver with folding mirror
-  2. Leveling status -LED for Y-axis (or Z-axis in case of laying arrangement)
Green 1x: Leveling < 0.04 mm/m;
2x: Leveling < 0.025 mm/m;
Red LED: Actuator motor working
-  3. Leveling status LED for X-axis
Green 1x: Leveling < 0.04 mm/m;
2x: Leveling < 0.025 mm/m;
Red LED: Actuator motor working
-  4. Power status LED on / off
-  5. Power key on/off
-  6. Laser rotation on/off
-  7. Key cross for setting the laser level 5(+)/ 6(-)
As well as 3(+)/4(-)
-  8. Self-leveling on/off
-  9. Leveling status LED on/off
-  10. Level for rough leveling of the appliance

Signals of T310

Buzzer

Permanent sound	<ul style="list-style-type: none"> • In leveling mode shock impact to T310 • One axis, which is in leveling mode is controlled by another controlling transmitter (IR, cable) • Calibration was accepted as valid • Boot loader call-up executed
5Hz-sound sequence	<ul style="list-style-type: none"> • Transport lock inserted • Pendulum movement error • Calibration value was not accepted
1Hz- sound sequence	<ul style="list-style-type: none"> • Rotation below 1Hz (blocked drive) • During rotational setting maximum /minimum rotational frequency reached
Clicking	<ul style="list-style-type: none"> • Switch-on frequency reached • Key pressed again • Key of the remote control pressed • Position regulation via R310 (IR or cable) supplies valid position value
Cyclic honking	<ul style="list-style-type: none"> • Supply voltages below their warning threshold

Power LED

Permanently active	<ul style="list-style-type: none"> • Switched on, no error, transport lock free, supply below warning level
5Hz-blinking	<ul style="list-style-type: none"> • Transport lock screwed in
1Hz- blinking	<ul style="list-style-type: none"> • Supply voltages below their warning threshold

ROTATIONAL LASER T310

Leveling LED

Permanently active	<ul style="list-style-type: none">• One or both axes are in leveling mode
5Hz-blinking	<ul style="list-style-type: none">• It is not possible to level one or both axes; outside valid leveling values, inclination too strong +/- 3° (ca 50mm/meter)
1Hz-blinking	<ul style="list-style-type: none">• Temperature is rapidly changing , leveling position not yet correct

Red (Y+)-LED

Permanently active	<ul style="list-style-type: none">• Drive running in (Y+)-direction (a large correction of the current level position is in progress)• In connection with green (Y+)-LED: Calibration was accepted for Y(Z) axis
5Hz-blinking	<ul style="list-style-type: none">• Y Drive Error.• Switch on/switch off sequence
Short pulse	<ul style="list-style-type: none">• (Y+)-key just pressed; first individual steps are driven

Red (Y-)-LED

Permanently active	<ul style="list-style-type: none">• Drive running in (Y+)-direction (a large correction of the current level position is in progress)• In connection with green (Y-)-LED: Calibration was accepted for Y(Z) axis
5Hz-blinking	<ul style="list-style-type: none">• Y Drive Error.• Flash error (check sum or boot sector wrong)• Calibration of the Y-axis was not accepted as position unstable.• Switch on/switch off sequence
Short pulse	<ul style="list-style-type: none">• (Y-)-key just pressed; first individual steps are driven

Red (X+)-LED

Permanently active	<ul style="list-style-type: none"> • Drive running in (X+)-direction (a large correction of the current level position is in progress) • In connection with green (X+)-LED: Calibration was accepted for X(Z) axis
5Hz-blinking	<ul style="list-style-type: none"> • X Drive Error. • Switch on/switch off sequence
Short pulse	<ul style="list-style-type: none"> • (X+)-key just pressed; first individual steps are driven

Red (X-)-LED

Permanently active	<ul style="list-style-type: none"> • Drive running in (X-)-direction (a large correction of the current level position is in progress) • In connection with green (X-)-LED: Calibration was accepted for X(Z) axis
5Hz-blinking	<ul style="list-style-type: none"> • X Drive Error. • Flash error (check sum or boot sector wrong) • Calibration of the X-axis was not accepted as position unstable. • Switch on/switch off sequence
Short pulse	<ul style="list-style-type: none"> • (X-)-key just pressed; first individual steps are driven

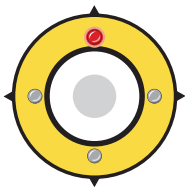

Red (Y+)-LED

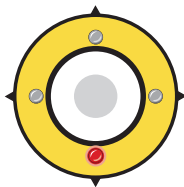

Red (Y-)-LED

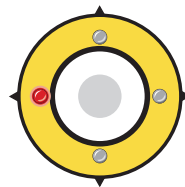

Red (X+)-LED

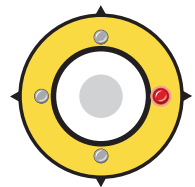

Red (X-)-LED

ROTATIONAL LASER T310

Green (Y+)-LED

Permanently active	<ul style="list-style-type: none">• Y+ axis is leveling. (Progress status: within 0.02mm/m of calibration)• In connection with red (Y+)-LED: calibration was accepted for Y(Z) axis
5Hz-blinking	<ul style="list-style-type: none">• Y+ axis is leveling. (Progress status: within 0.2mm/m of calibration)• Valid protocol received from R310 (via IR or cable)
1Hz-blinking	<ul style="list-style-type: none">• Y+ axis leveling in progress

Green (Y-)-LED

Permanently active	<ul style="list-style-type: none">• Y- axis is leveling. (Progress status: within 0.02mm/m of calibration)• In connection with red (Y-)-LED: calibration was accepted for Y(Z) axis
5Hz-blinking	<ul style="list-style-type: none">• Y- axis is leveling. (Progress status: within 0.2mm/m of calibration)• Valid protocol received from R310 (via IR or cable)
1Hz-blinking	<ul style="list-style-type: none">• Y- axis leveling in progress

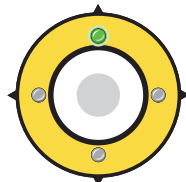

Green (Y+)-LED

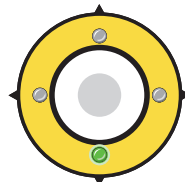

Green (Y-)-LED

Green (X+)-LED

Permanently active	<ul style="list-style-type: none"> • X+ axis is leveling. (Progress status: within 0.02mm/m of calibration) • In connection with red (X+)-LED: calibration was accepted for X(Z) axis
5Hz-blinking	<ul style="list-style-type: none"> • X+ axis is leveling. (Progress status: within 0.2mm/m of calibration) • Valid protocol received from R310 (via IR or cable)
1Hz-blinking	<ul style="list-style-type: none"> • X+ axis leveling in progress

Green (X-)-LED

Permanently active	<ul style="list-style-type: none"> • X- axis is leveling. (Progress status: within 0.02mm/m of calibration) • In connection with red (X-)-LED: calibration was accepted for X(Z) axis
5Hz-blinking	<ul style="list-style-type: none"> • X- axis is leveling. (Progress status: within 0.2mm/m of calibration) • Valid protocol received from R310 (via IR or cable)
1Hz-blinking	<ul style="list-style-type: none"> • X- axis leveling in progress

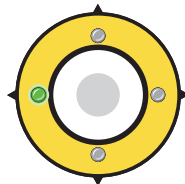

Green (X+)-LED

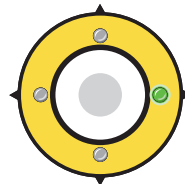

Green (X-)-LED

ROTATIONAL LASER T310

Structure of laser sender T310

The T310 can be mounted onto the BG 830205 adapter standing upright or lying on its side.

Standing upright, the rotating beam forms a horizontal level. The vertical beam is then always orthogonal to it. Lying on its side, the rotating beam forms a vertical plumb surface.

The BG 830205 adapter can be placed directly onto the measuring object by means of its magnetic feet.

The BG 830205 can then be fixed to a tripod by means of a standard tripod adapter.

Upright setup

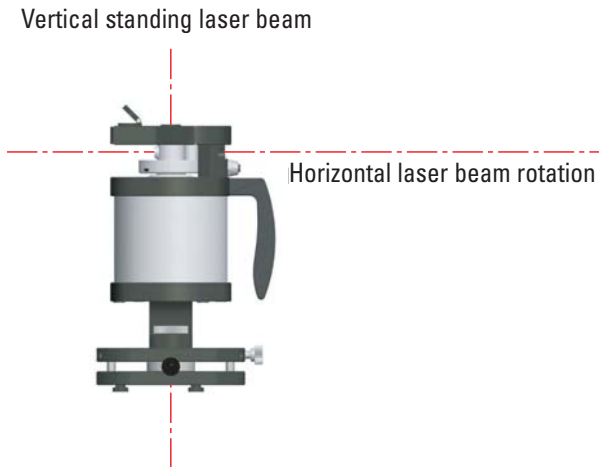

Lying setup

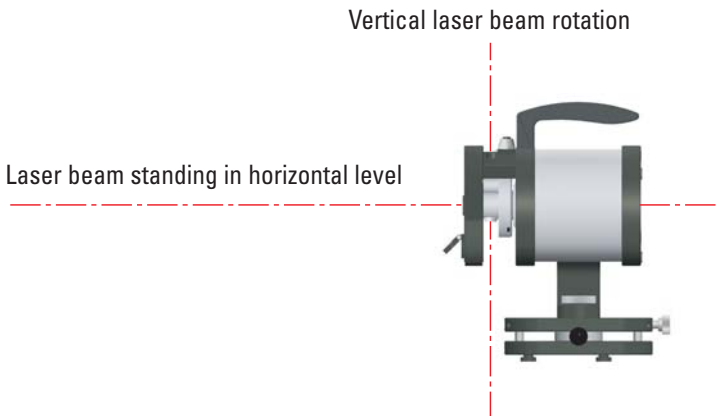

Field calibration

For best results the calibration for the leveling should be carried out before measuring. The X- and Y-axes are calibrated independently of each other. Calibration of one axis with a major error in the self-leveling may also affect the other axis.



Note

Before starting the calibration, the T310 should have reached operating temperature. Check the leveling-LEDs. The minimum basic width for carrying out field calibration is 2 m (6 ft).

Step 1:

- Place the T310 onto a level surface (+ / -1 cm/m)
- Place the R310 in direction of Y-axis in at least 2 m (6 ft) distance.



Switch on the T310 and R310. Wait approx 30 minutes for the unit to acclimatize.



Switch on rotation and self-leveling.



Wait until all 4 leveling status-LEDs glow green.



“Zero” the R310.

Step 2:



Turn the T310 exactly 180°. The R310 is not on the Y-axis. Due to the change, the self-leveling is automatically switched off. Switch the self-leveling on again.



Wait until all 4 leveling status-LEDs low green. (normally 2 minutes)



Press the 1/2 key of the R310. The R310 now shows the leveling error in the Y-axis.

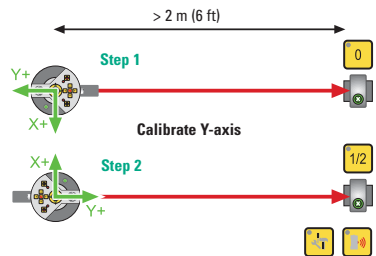

ROTATIONAL LASER T310



This error can now be corrected. Now select function POS Y from the R310 setup menu.



Switch on the IR-control. The R310 will now send messages to the T310, which will correct the laser level in the Y-axis to zero.



Select function CAL Y from the setup menu to set the new calibration of the Y-axis.



As soon as the T310 receives the CAL Y-command from the R310, it will stop rotating and display the calibrated axis with red LEDs.

The Y-axis is now calibrated.

The same procedure can be carried out for the X-axis.

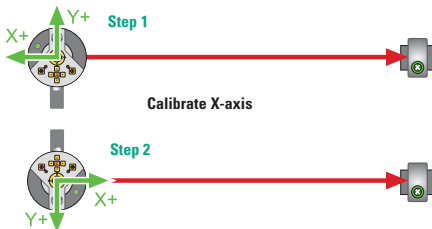

Exchanging batteries



Exchanging the batteries/rechargeable batteries T310

To exchange the batteries/rechargeable batteries proceed as follows:

1. Turn the T310 in a way that the bottom is easily accessible.
2. Open the battery compartment with a screwdriver (remove 1 screw).
3. Note the polarity of the batteries/rechargeable batteries.
4. Replace the batteries/rechargeable batteries with new batteries or recharged batteries, type Mignon 1.5 V, AA / LR6.
5. When inserting the new the batteries /rechargeable batteries observe correct polarity.
6. Screw battery compartment closed.
7. Check function by switching on the T310.



Danger!

Normal batteries must not be charged, heated or thrown into open fire (danger of explosion!). Do not insert different batteries/rechargeable batteries. Always use one kind of the respective type! Never use old and new batteries/rechargeable batteries together.

ROTATIONAL LASER T310

Technical information

	T310-A	T310-B
Laser protection class	2	2
Measuring distance	0 to 50m (0 to 150ft)	0 to 50m (0 to 150ft)
Prism error	< 0.02 mRad (mils/inch)	< 0.02 mRad (mils/inch)
Step error	± 0.05 mm (2 mils)	± 0.1 mm (4 mils)
Conical error	± 0.01 mRad (mils/inch)	± 0.02 mRad (mils/inch)
Self-leveling accuracy	± 0.02 mRad (mils/inch)	± 0.02 mRad (mils/inch)
Temperature sensitivity:		
Static temperature coefficient	0.001 mRad/K	0.01 mRad/K
Dynamic temperature coefficient	0.005 mRad/K/min	0.05 mRad/K/min
Environmental conditions:		
Temperature	0°C to +50°C (32F- 120F)	0°C to +50°C (32F- 120F)
Air humidity	20% to 80%	20% to 80%
Power supply	8 batteries 1.5 V, type Mignon (AA/LR6) or A/C adapter	8 batteries 1.5 V, type Mignon (AA/LR6) or A/C adapter
Running time	> 10 hours permanent operation with batteries/rechargeable batteries (depending on capacity)	> 10 hours permanent operation with batteries/rechargeable batteries (depending on capacity)
Dimensions	125 x 170 x 185 mm (4.8 x 6.6 x 7.2 in)	125 x 170 x 185 mm (4.8 x 6.6 x 7.2 in)
Weight	2400 g (5.25 lbs)	2400 g (5.25 lbs)

Explanation of types of prism deviations

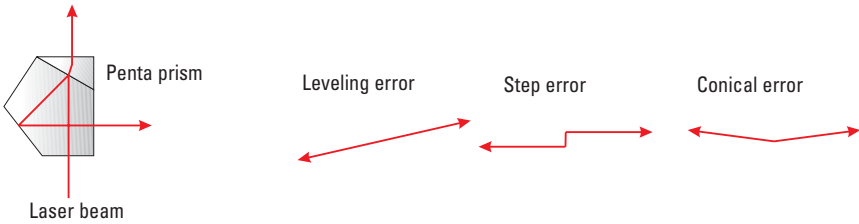

Dimensions

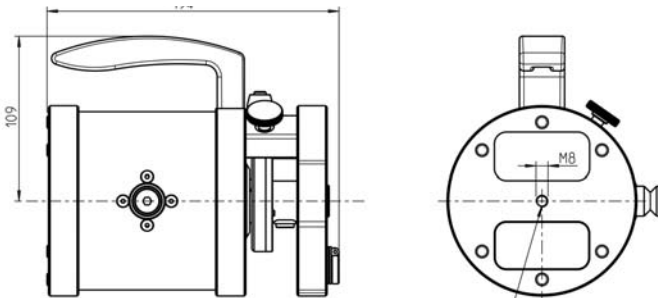

M8 (8 mm deep) thread drilling for fastening

LASER BEAM RECEIVER R310

Operation

Part No. BG 830100

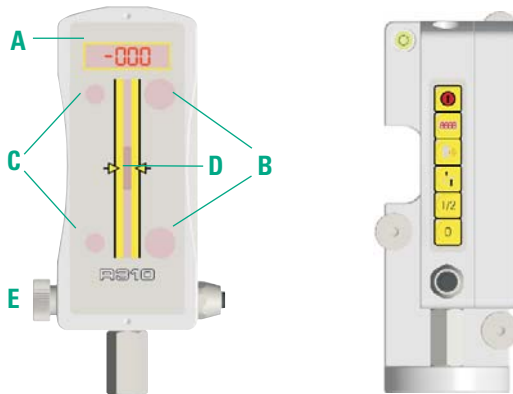







The measured position values are displayed in display **A**. The infrared communication between T310 and R310 happens via the IR senders **B**. The position LEDs **C** show the settings (status active / inactive) in the setup menu; both LEDs, top and bottom, glow. In case of inactive values or setting parameters the LEDs are off. Here, the laser beam of the T310 hits the receiver surface **D**. The fastening screw **E** holds the R310 in position.

During measuring operation, the position LEDs (C) show the receiver position of the R310 in relation to the laser level:

- R310 is too low / beam above 0: **Red LED on top glows.**
- R310 is too high / beam below 0: **Red LED on the bottom glows.**
- Laser hits in the range of ± 0.1 mm (close range): **LEDs top and bottom glow.**

Operating elements

The operating keys of the receiver R310 control various functions. The LED in the left upper corner of the operating keys shows whether the function is currently selected.

- | | | | |
|--|--|---|--|
|  | 1. Power On/Off
Switching On / Off or during operation leaving 'Exit' the setup menu |  | 4. Setup
Activate setup menu (settings) |
|  | 2. Display of measuring values
on/off |  | 5. Half Zero Shift
Shifts the current Zero scale by 1/2 the current measured value. |
|  | 3. IR infrared / cable control
on/off |  | 6. Zero position Displayed value is set to zero (set function in the setup menu, see description below) |

Setup menu

Repeated pressing of the 4 setup key switches through the various setting levels of the setup menu.

The position LEDs C show whether a setting is selected active or inactive. In case of active setting both position LEDs glow (yellow/red), in case of inactive setting the position LEDs are off.

Pressing key 6 "0" allows switching between "active" and "inactive".

If "active" is switched, the display shows "Set" for 3 seconds.

If "inactive" is switched the display shows "Clr" for 3 seconds.

To leave the setup menus, press key 6 zero position "0".

Setting options of the setup menu:

Only valid for the current firmware versions: **T310: V 1.11 / R310: V 5.11**, version 20.01.2007

PC:	PC communication active	BEEP:	Signal sound active / inactive
dU20:	DU 20 communication Active	ANGLE:	Current sensor angle +/- 0.2 degrees
dU30:	DU 30 communication Active	rc310:	Position data for RC310 (for viewing)
EU:	Unit in mm	CAL X:	Calibration X-axis; X-axis zeroed
US:	Unit in inch	CAL Y:	Calibration Y-axis; Y-axis zeroed
Ir310:	IR-laser control active	CAL Z:	Calibration Z-axis; Z-axis zeroed
Cb310:	Cable- laser control active	nEAR:	Setup for measuring distance < 25 m (< 82 ft) optimized
PoS X:	Position data for X-axis of the T310 (External Level regulation)	FAR :	Setup for measuring distance > 25 m (> 82 ft) optimized
PoS Y:	Position data for Y-axis of the T310 (External Level regulation)	U xx.x:	Current battery voltage
PoS Z:	Position data for Z-axis of the T310 (External Level regulation)	C xx.x:	Current temperature in °C (in detector)
AG Lo:	Fast message is active (measuring value reached faster, less averaging)	AAx.xx:	Software version.
AG Hi:	Slower message is active (measuring value reached more slowly, value more stable)		

For the groups combined according to color, only one setting can be active at a time.



Note

The receiver saves the set values even if the appliance is switched off or batteries are changed.

Explanation of the settings

- **PC / dU20 / dU30** define the communication with the external appliances (either PC or DU20 or DU30).
- **EU/US:** Measuring information metric EU in mm US inches.
- **Ir310 / Cb310** determine the communication between laser and receiver (either IR (infrared) or cable).
- **PoS X / PoS Y / PoS Z:** Here we select the axis of the opposing T310 which should be controlled by this R310 Sensor be it via IR (infrared) or cable.
- **AvG Hi:** High mean sample. Response time slower
- **AvG Lo:** Low mean sample. Response time faster.
- **nEAR / Far:** The R310 evaluates the laser beam before representing the measuring value. In case of large distances > 98.43 ft the length of stay of the laser beam on the detector is much shorter. The beam is also more affected by temperature differences and air movements. With setting nEAR / FAR, the user can account for these influences and optimize the evaluation.
- **ANGLE display setting:** If ANGLE is active the R310 represents continuously the current angle of rotation of the sensor housing.
- **U (voltage) and C (temperature)** display the voltage of the batteries/ rechargeable batteries in V and temperature in °C.
- **CAL X/ CAL Y/ CAL Z"** are settings for the laser sender T310 when executing a field calibration. They are normally sent either via IR (infrared) or cable.

Status and error messages

When switched on, the display first shows the communication protocol and the selected unit, e.g. (PC / dU20 / dU30 and EU / US).

PC EU	(Example) When switched on, the R310 displays his communication protocol and scale.
no In	ANGLE pressed and R310 without inbuilt inclinometer.
8.8.8.8.8.	ANGLE pressed and inclinometer not calibrated.
Set	Menu item activated.
CLr	Setting in the setup menu deactivated.
boot 1	Boot loader program active. R310 waiting for new software from PC.
boot 2	FPGA-Boot loader program active. R310 waiting for new software from PC.
SLEEP	R310 being switched off.

Structure of the R310 receiver

With the holding screw **H**, fix the R310 receiver to the measuring adapter on the magnetic foot **M**.

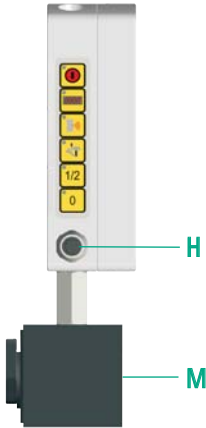

The measuring adapter ensures precise fixing of the receiver and therefore highest reproducibility and measuring exactness!



Magnetic foot and magnetic stand adapter

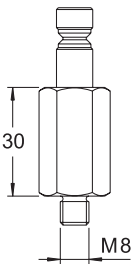

Magnetic stand adapter
Part No. FIX 1-0629



Magnetic foot
Part No. FIX 1-0083

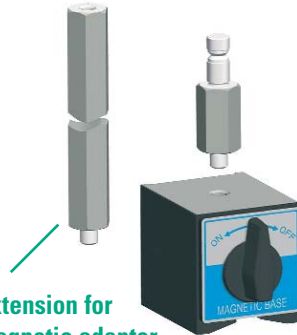

Extension for magnetic adapter
PPart No.

80 mm: FIX 1-0658-080
300 mm: FIX 1-0658-300
600 mm: FIX 1-0658-600
900 mm: FIX 1-0658-900

General information

The measuring system T310 can almost completely be operated with the RC 310 remote controls. This ensures swift processing when carrying out extensive measuring operations. In addition, the measuring values of the receiver are transmitted to the display of the remote controls. As a reading aid, it shows the regulation position values in case of regulation via R310, in case of a calibration command, it shows the sent command with name, and in case of a viewing command it shows the display value of the R310. For each newly received IR-command, there is a short clicking sound, similar to a key clicking. The operating keys can be operated as described in the overview on page 6, like the keys of the T310.



Operating keys RC310



Power Taste on/off as well as self-leveling on/off



Laser rotation on/off, after switching off the laser is stopped and held in parking position



Key cross for adjustment of the laser level
▲ (+) / ▼ (-) as well as ◀ (+) / ▶ (-)



Note

For error-free function of the remote controls please ensure that there is a clear view between the IR-communication sensors of the R310 (see page 11) and the RC310.

Information concerning use

With the RC310 infrared remote controls the most important functions can be easily operated without the need to be close by. Identical inscription on remote controls and T310 means identical functions.

Some keys are only available on the T310. The corresponding functions can only be operated on the T310.

For remote control operation, please observe the following:

- Point remote controls (sender) at the receiver R310.

- Visual connection between sender and receiver of the R310 must be ensured.
- If the reach of the remote controls declines, the batteries should be replaced with new ones.

Communication between RC310 remote controls and R310 sensor

There are three message types that the R310 receiver can send to the RC310:

- Position data without regulating function (current display value of the R310)
- Position data with regulating function of the laser sender T310
- Calibration commands for all three axes of the T310 laser sender

Position data without regulating function (current display value of the R310):

This function serves to read the measuring value of a R310 that may be further away. The value displayed on the RC310 is the value displayed on the R310.



For this, menu item “rc310” must be activated on the R310. To do so, use the “Tool” key to step to display “rc310”.



This menu is then activated with the “0” key. Briefly, “Set” is shown on the display of the R310 (active menu items are also indicated by the glowing position-LEDs).



Leave the Tool menu with the “On” key Tool menu.



To activate the positions transmission the “IR” key must be pressed.



Note

The R310 only sends position data if a beam is recognized.

The display of the RC310 remote controls shows the display values of the R310.



Attention:

With each new key operation on the R310 the IR-sending function is terminated. Whether sending takes place or not is indicated with the LED or the “IR” key.



Note

In case of unavailable IR-communication the last display content will remain for about 2 seconds.

The RC310 remote controls receive a new position value every 500ms. This is indicated by a clicking sound on the RC310.

Position data with regulating function of the T310

These data form the position values for regulating the T310. They deviate slightly from the display values shown on the R310, since for regulation, the position values are treated differently. The informative content of these values is not as significant as in the previous point. Here it is easier to recognize the size of a deviation as well as its tendency, e.g. if the regulation is subject to a strong error.

If the R310 remote controls regulate the T310 receiver, position data are sent that can also be received by the RC310. To do so, the regulation on the R310 must be active. On the display of the RC310 the regulated axis designation is represented in addition to the regulating values.

Calibration commands for all three axes of the T310

If the R310 sends one of the calibration commands, the RC310 also recognizes this command and shows its name for about 2 seconds. This way, it is also possible to see that the command was sent. This function is purely informative.

Operation

Switching on



The RC310 is switched on with the lower right key. Switching on is followed by information for about one second about the company name, appliance designation and the software version. Then all keys are shown as symbols as well as the appliance designation. This is the display for normal operation.

Switching off



To switch off, the lower right key is pressed for more than 1.5 seconds. If the key is pressed longer a reminder sound is released indicating to the operator that the key should be released.

Configuration of the RC310

Configuration includes language (German, English, French), contrast and background illumination. In addition this displays the software version, internal check sum, battery voltage and temperature.



To get into this mode, key 6 must be pressed (and held), then key 5 in addition.

In the menus the keys 6 and 5 can be used to change the displayed settings (the contrast menu contains a scroll function). 4 is used to save the represented setting and to change into the next menu. After the last menu, normal operation is called up again.

Reset function

The reset function serves to reset the factory settings (language: German; contrast: 40; background illumination: off).



To carry out the reset function, the keys 3, 5, 4 must be pressed in this sequence and held.



Note

The maximum distance between remote controls and receiver is 164 feet.

Measuring set in suitcase



Content:

- power adapter
- rechargeable batteries
- T310 with rotating and swivel adapter
- 3 x measuring adapter R310
- 3 x magnetic foot with measuring adapter for R310
- 3 x wall/floor adapter for R310



Main components

Image	Part No.	Description
	BG 830200/1	Self-leveling rotational laser T310, RS485 Bus Interface
	BG 830100	Laser receiver R310 with display
	SP RC310 / BG 830930	Remote controls RC310 with display
	SP-R525-P / BG 830390	Laser detector psd 20*20 with rechargeable battery R525

Mechanical parts / tripod

Image	Part No.	Description
	BG 830205	Rotating and swivel adapter for laser T310
	FIX 1-0083	Magnetic foot with level surface
	FIX 1-0629	Measuring adapter for R310, M8, 30 mm
	FIX 1-0658-080	Extension for measuring adapter FIX 1-0629, M8, 80 mm
	FIX 1-0658-300	Extension for measuring adapter FIX 1-0629, M8 300 mm
	FIX 1-0658-600	Extension for measuring adapter FIX 1-0629, M8 600 mm
	FIX 1-0658-900	Extension for measuring adapter FIX 1-0629, M8 900 mm
	FIX 1-0613 / BG 830117	R310 wall / floor adapter



Mechanical parts / tripod

Image	Part No.	Description
	FIX STATIV-01-P	Tripod 545 mm - 935 mm (21.46 in - 36.81 in)
	FIX STATIV-02-P	Tripod 870 mm - 1900 mm (34.25 in - 74.80 in)
	FIX STATIV-03-P	Tripod 1160 mm - 2520 mm (45.67 in - 99.21 in)
	FIX STATIV-04-P	Tripod 1880 mm - 3910 mm (74.02 in - 153.94 in)

Power supply / cable / interface

Part No.	Description
FIX 1-0632	R310 bus supply and RS485 - 232 converter
FIX 9-2001	T- distributor for T310 and R310 bus 230 V AC EU
BG 800110	Power supply R-310/T-310
FIX 1-0210	Cable for TD-M,TD-S and DU-20/30, 10m (32.8 ft)
FIX 1-0211	Cable for TD-M,TD-S and DU-20/30, 25m (82.0 ft)
FIX 1-0222	Cable for TD-M,TD-S and DU-20/30, 1m (3.28 ft)

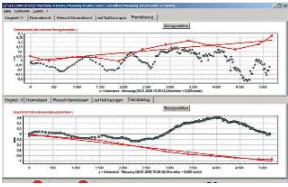



Evaluation PC / DU

Image	Part No.	Description
	SP-SW2003	PC Software Geo 2003 Applications SW
	SP TRView	PC Software R310 + T310 measuring value database archiving
	IT 200200	DU310 – Ultramobile PC based

Accessories

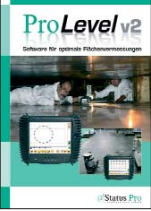
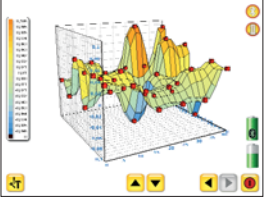
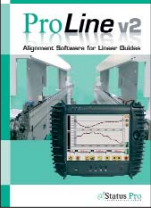
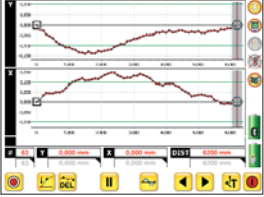
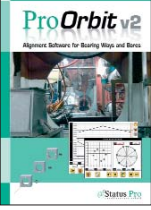
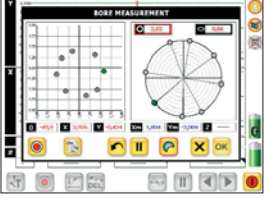
Part No.	Description
BG 830111	R310 battery compartment casing

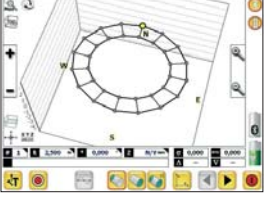
Additional Software to use with DU310

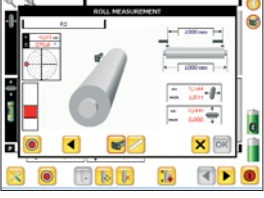
Software	Description
 <p>ProLevel v2 Software for optimum Flächenmessungen</p>	<p>ProLevel v2 Software for Optimum Surface Measurements</p> 
 <p>ProLine v2 Alignment Software for Linear Guides</p>	<p>ProLine v2 Alignment Software for Linear Guides</p> 
 <p>ProOrbit v2 Alignment Software for Bearing Ways and Bores</p>	<p>ProOrbit v2 Alignment Software for Bearing Ways and Bores</p> 
 <p>ProFlange v2 Software for Optimum Flange Measurement</p>	<p>ProFlange v2 Software for Optimum Flange Measurement</p> 
 <p>ProRoll v2 Parallel roll alignment software</p>	<p>ProRoll v2 Parallel Roll Alignment Software</p> 



SEIFFERT
INDUSTRIAL, INC.

Industrial Laser Alignment Systems



Seiffert Industrial, Inc.
1323 Columbia Drive · Suite 305
Richardson, TX 75081
Phone: 972-671-9465
Fax: 972-671-9468
info@seiffertindustrial.com
www.seiffertindustrial.com



 **Status Pro**
maschinenmesstechnik

Status Pro Maschinenmesstechnik GmbH
Mausegatt 19
D-44866 Bochum
Phone: + 49 (0) 2327 - 9881 - 0
Fax: + 49 (0) 2327 - 9881 - 81
www.statuspro.com
info@statuspro.com

BA 0154E 02/09 · Design / DTP: Seichter & Steffens Grafikdesign, D-44229 Dortmund

Copyright 2009 Status Pro Maschinenmesstechnik GmbH. This user guide or parts thereof may not be copied or otherwise reproduced without explicit written from the management of Status Pro GmbH. The technical details are subject to change without notification. We would appreciate being informed of any errors in this manual.